

## USER MANUAL

**THIS USER MANUAL SHOULD BE READ THOROUGHLY, UNDERSTOOD, AND KEPT FOR FUTURE REFERENCE, BEFORE STARTING THE WORK**

The application of this user manual is subject to the most recent version. Upon establishment of a revised and/or amended version, all previous versions will become invalid. Consult your supplier for the latest version.

### **Anchor clamp for hollow core slabs 2906APV038001**

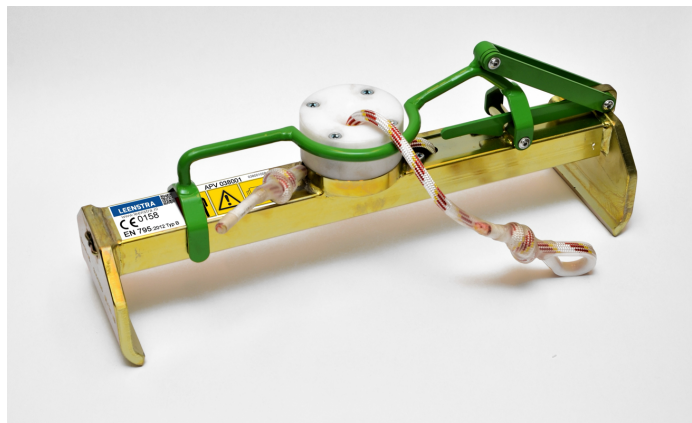

**Anchor point according to EN795:2012 TYP B  
Anchor clamp for hollow core slabs type APV 038001  
And  
energy absorbing lanyard  
according to EN 354:2002 / EN355:2002, Type Miller 1032380  
Or  
(C) automatic retractor according to EN 360:2002  
Type IKAR HWPS3  
And  
Harness according to EN361:2002, Type Teufelberger Ergo**

Weight of the anchor clamp is approximately 9 kg. This fall arrestor may only be used for PPE against falling.



- 1. Initial check**
- 2. Cooperation with the crane operator**
- 3. Use of the Van der Blij fall arrestor**
- 4. Location of the anchor clamp**
- 5. Repositioning the anchor clamp**
- 6. Inspection - certification**
- 7. Maintenance**
- 8. Retail to foreign countries**
- 9. Warning**
- 10. Anchor point service life**
- 11. Year of manufacture**
- 12. Type A with energy absorbing lanyard**
- 13. Type C with automatic retractor**

The aim of this user manual is to provide the user with information to enable the correct, efficient and safe use of the product during its service life. The product is only intended for professional use and in a professional environment. This user manual is based on that assumption.

Van der Blij B.V. has endeavoured to describe the use, maintenance and risks related to the product as thoroughly and complete as possible. However, it is not possible to describe all conceivable risks. This user manual therefore only concerns the normal and careful use of the product as well as reasonable foreseeable improper use thereof.

Other rules and instructions may apply in addition to the instructions and notes in this user manual. For example, rules ensuing from Working Conditions Regulations and/or a H&S plan. This user manual only concerns the use of the product.

In all cases where we act as tendering party or supplier, our quotations, orders placed with us and agreements concluded with us are subject to the METAALUNIE TERMS & CONDITIONS. These terms and conditions are filed at the Registry of the Court of Rotterdam. These terms and conditions have been sent as an attachment to the quotation and/or order confirmation and invoice that you have received from us.

(Images in this user manual are for illustrative purposes and may differ from the actual product delivered).

### Initial check

Please check if the Van der Blij fall arrestor is suitable for the slabs you are working with (see figure 1). The fall arrestor fits almost all brands of prefab floors slabs.

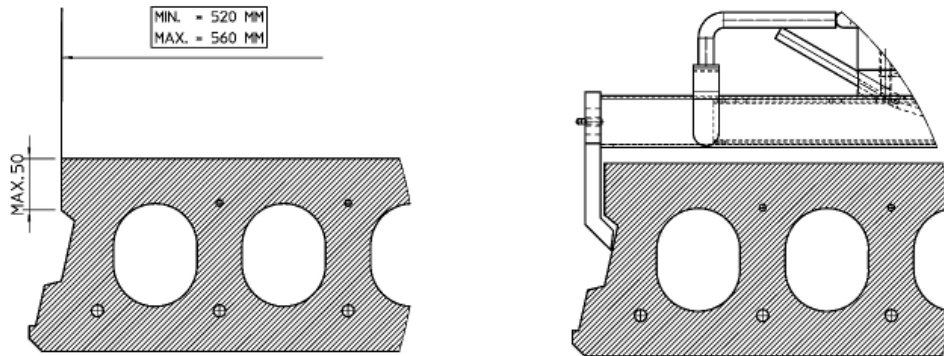

Figure 1

### Also check

The quality of the profile the clamp fits on must be visually checked for cracks or other signs of quality defects.

The width of the floor slabs must be 60 cm.

Check if the grip fits correctly into the groove.

Is the anchor point clean?

Is the anchor point suitable for the purpose you are using it for?

Test the clamp function by pulling the anchor rope after each placing.

Before every use a visual check of all components of the system is mandatory. Pay attention to that all functions are working well and there is no wear of ropes etcetera.

We also advise you to read the user manuals of the separate components.

### Cooperation with the crane operator

Before mounting, the crane operator should be aware that the mechanics, when using the Van der Blij fall arrestor, are restrained in their movements. The placing of the hollow core slabs by the crane demands the utmost safety.

### Use of the Van der Blij fall arrestor

In case of falling risk, additional safety measures for fall protection must be made. From a free fall height for Type A - 3,75 meter and for Type C - 3,03 meter the Van der Blij Fall Arrestor can be used. These heights are inclusive 1 meter safety distance according to the norm.

An action plan for rescue operations must be present in which all imaginable emergencies are taken into account.

The user of this safety system should be in good health.

The user must have read and have understood the user manual before using this fall arrestor.

Each other use as described in the user manual is not allowed.

We advise to use this safety anchor as personal equipment.

The safety system should be used without breaks during working on the hollow core floor slabs. When the user does not apply this in practice, this will cause dangerous situations.

The tolerable application temperature: -20 till +50 °C.

All labelling should be available and readable

### Location of the anchor clamp

The position of the clamp should be chosen in a way that in case of an accident the secured person at any time hangs on the fall arrestor system and not reaches the floor below.

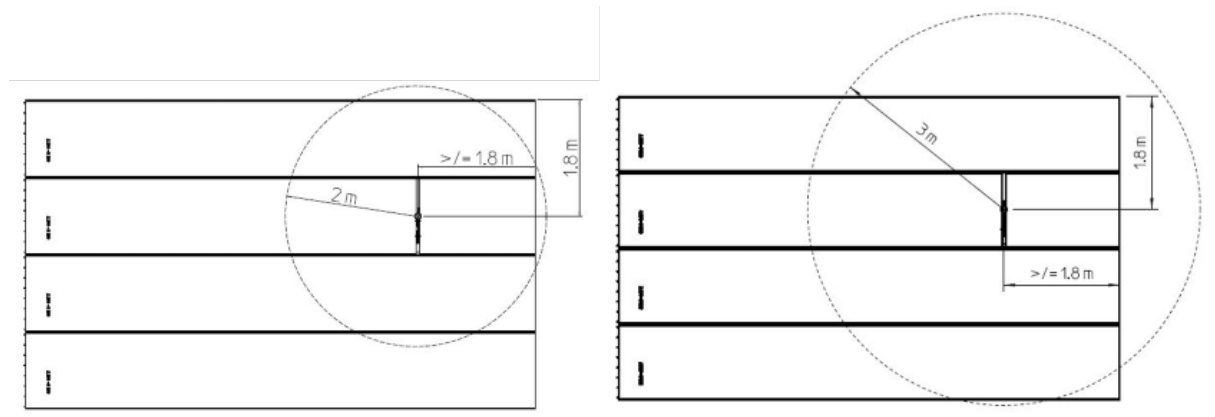

Figure 2

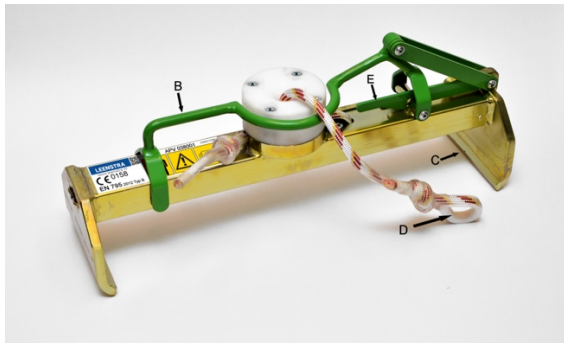

Figure 3

See figure 3.

Place the anchor clamp in such a way that the grip is located away from the laying front. Please be careful and beware of stumbling.

Hook grip 'C' in the groove of the slab.

Unlock with the help of grip E, handle B.

Pull out the clamp with handle 'B' until the grip hooks around the groove on the other side of the slab.

Release the handle and check if the handle falls into the rest position and is blocked by grip E.

Check if both grips fit properly into the grooves of the floor slab.

Pull the anchor rope so that you can test whether the clamp is locked well after each installation.

You can fasten yourselves to the eye D of the rope to the lanyard (type A) or with the automatic retractor (type C).

### Repositioning the anchor clamp

See figure 3.

Unlock with the help of grip E, handle B.

Pull with handle 'B' the clamp apart and lift the clamp out of the joint of the concrete slab.

Move the anchor point according to figure 2.

Be sure there is no danger of falling whilst moving the clamp.

There is any doubt about the safe condition of the system.

The fall arrestor has been actually used to stop a fall.

The period between the regular inspections is more than 12 months.



The complete fall arrestor may not be used any more and has to be checked by the manufacturer in case:

One or more parts of this fall arrestor are damaged or broken.

There is any doubt about the safe condition of the system.

The fall arrestor has been actually used to stop a fall.

The period between the regular inspections is more than 12 months.

### **Inspection and certification**

The VDB fall protection clamps must be inspected annually. Inspections and repairs must be carried out by the manufacturer or a person trained by the manufacturer. Van der Blij B.V. can train individuals to ensure that this inspection is conducted correctly in accordance with, among other things, sections 4.4 c, d, and e of NEN-EN 365.

### **Maintenance**

After each use, the system has to be cleaned and has to be free of concrete and mortar rests. Take good care that there is no pollution in the Van der Blij anchor clamp. Parts may not be lubricated. The sticking effect of fats causes a dirt accumulation with detrimental effect.

When the system is wet, it prefers to let dry the system in a natural way. Do not use hot air. The system should be stored dry and clean. Please store the system in a light-proof bag in order to prevent the ageing process of the rope. Van der Blij has appropriate equipment for this purpose.

Do only use water for cleaning.

Take good care that the fall arrest system is packed correctly during transport in order to prevent damage. Van der Blij has appropriate equipment for this purpose.

All parts of the system must be kept away from welding light and -sparks, fire, acids, alkalis and all comparable fluids.

### **Retail to foreign countries**

When the Van der Blij safety anchor will be sold to countries with another user language then originally delivered, the seller is obliged to deliver this user manual in the user language.

### **Warning**

In the preceding text, we advise you to which the hollow core element must conform before using this system. Van der Blij B.V. cannot be held responsible any consequences caused by unwise or incorrect used of the fall arrest system. For elements that do not conform to the stated specifications or if there is any doubt about the suitability of the system, we request you to contact Van der Blij B.V. If necessary Van der Blij can do tests with your type of floor element.

Attention! Changes to the equipment or replacements without preceding written permission of the manufacturer are not allowed and all repairs may only be performed with measures, stated by the manufacturer.

Attention! Danger can occur when one combines single elements of the equipment in case the protected function of one of the elements or components or the composed equipment is obstructed.

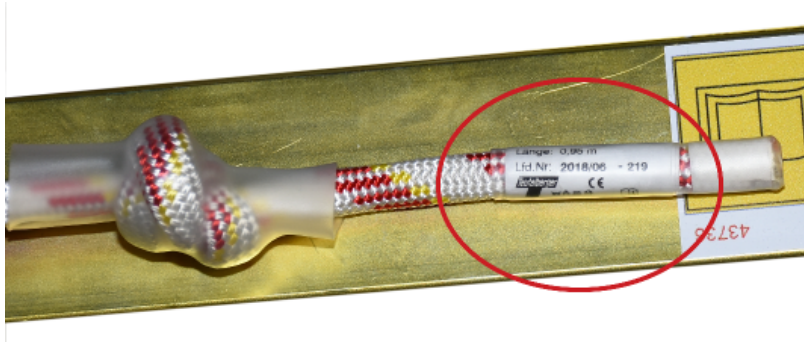

### Anchor point service life

The anchor point (terminal) has an unlimited service life, provided it has been tested (approved) less than a year ago and meets the standard. The anchor line in the anchor point has a limited service life of up to 5 years after the use of the clamp (anchor point) or 6 years after the production date of the line (visible on the line, see image).

### Year of manufacture

The year of manufacture is indicated in the serial number. The left number shows the century (A) and the two numbers next to it (B) are the year. The next two numbers (C) indicate the month. The following numbers indicate the serial number of the production. Example 2180931 = September 2018 with serial number 31.

The position of the serial number is indicated on the last page of this manual.



### Type A with energy absorbing lanyard (Art.-nummer 1032380)

Description of components (figure 4):

- 1.PA-PES O11mm line lanyard (tearing strength tested on sharp edge)
- 2.PES energy absorber with Miller Logo, Serial-und Article-number (edge tested)
- 3.Connector is compliant with standard (EN 362:2005) (D link on back of harness)
- 4.Connector is compliant with standard (EN 362:2005) (anchor side)

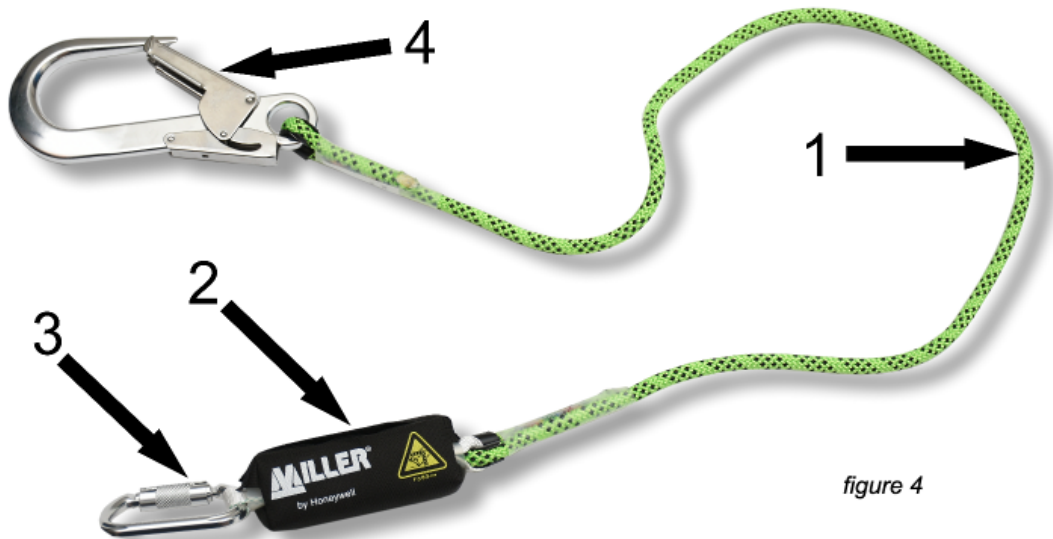

figure 4

Attach the end with the absorber(3) to the back D-link of the harness.  
Lanyard end (4) is attached to the anchor clamp. See also figure 4a.

The maximum length of this lanyard is 2m, including all the karabiners, and it is not allowed to be lengthened.



Figure 4a

**Type C with automatic retractor (Art.-nummer HWPS3)**

Description of all elements (figure 5):

1. steel cable (edge tested)
2. automatic retractor with brake
3. connector is compliant with standard (EN 362:2005) (D link on back of harness)
4. connector is compliant with standard (EN 362:2005) (anchor side)



figure 5

The end with the steel cable (3) must be connected with the D-ring on the back side of the harness.

The end of the retractor (4) must be connected to the eye (D) of the anchor clamp. See also figure 5a.

The length of the steel cable including all the karabiners and retractor is 3 m and may not be lengthened.



Figure 5a



## Explanation of markings

